



Rottweg 17 • D 48683 Ahaus
Tel. (0 25 61) 93 84-0
Fax (0 25 61) 93 84 36
Internet: www.ab-maschinen.de
E-Mail: info@ab-maschinen.de

Schweißtechnik
Lagereinrichtungen
Industriebedarf
Werksvertretungen
Gebrauchtmaschinen

MB PRO 1 (1008-845900)

© A + B Werkzeuge Maschinen Handels GmbH



Control type
konventionell

Machine no.
1008-845900

Make
MB

Location
Ahaus

Furnishing:

- Precise drive unit with face plate, on a stable floor stand.
- clockwise / counterclockwise
- 2 speed series, stepless
- Swivel range from 0 ° - 90 °. Manual tilt
- DC gear motor with worm gear, infinitely variable.
- diameter of 300 mm. Chrome-plated surface to protect against weld spatter.
- The device's control panel is easy to understand and use.
- Start / stop via a location-independent foot switch.
- The speed and direction of rotation are set on the machine.
- HF protected.

Scope of delivery:

- control (integrated)
- foot switch

Machine attributes

total power requirement:	230 Volt
table diameter:	300 mm
table load:	100 Horizontal kg
swivelling range:	0 - 90 Grad
turning speeds:	0,2 - 2,0 U/min
turning speeds:	1,2 - 12,0 U/min
bore:	20,0 mm
weight of the machine ca.:	50 kg
dimensions of the machine ca.:	480 x 325 x 470 mm

Machine images

© A + B Werkzeuge Maschinen Handels GmbH



© A + B Werkzeuge Maschinen Handels GmbH





Rottweg 17 • D 48683 Ahaus
Tel. (0 25 61) 93 84-0
Fax (0 25 61) 93 84 36
Internet: www.ab-maschinen.de
E-Mail: info@ab-maschinen.de

Schweißtechnik
Lagereinrichtungen
Industriebedarf
Werkvertretungen
Gebrauchsmaschinen

© A + B Werkzeuge Maschinen Handels GmbH

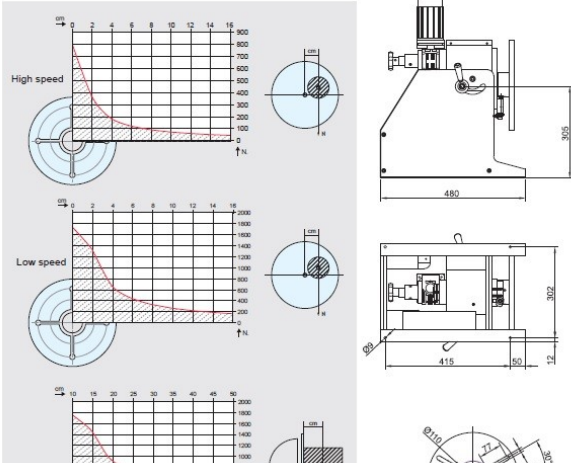

© A + B Werkzeuge Maschinen Handels GmbH



© A + B Werkzeuge Maschinen Handels GmbH



© A + B Werkzeuge Maschinen Handels GmbH



© A + B Werkzeuge Maschinen Handels GmbH



Rottweg 17 • D 48683 Ahaus
Tel. (0 25 61) 93 84-0
Fax (0 25 61) 93 84 36
Internet: www.ab-maschinen.de
E-Mail: info@ab-maschinen.de

Schweißtechnik
Lagereinrichtungen
Industriebedarf
Werkvertretungen
Gebrauchtmachines

